



USER MANUAL

LFB14k-51.2V280AH



contents

1.TECHNICAL DATA	01
2.PRODUCT OVERVIEW	03
2.1 brief introduction	03
2.2 Interface Introduction	04
2.2.1 Switch ON/OFF	04
2.2.2 Interface Introduction	05
2.2.3 Explanation of LED light changes	06
2.2.4 Power indicator light description	06
3.INSTALLATION GUIDE	07
3.1 Checking Before Installation	07
3.1.1 Checking Outer Packing Materials	07
3.1.2 Cheeking Deliverables	07
3.2 Tools	09
3.3 Installation requirements	10
3.3.1 Installation environment requirements	10
3.3.2 Installation carrier requirements	10
4.MAINTENANCE	13
4.1 Recharge Requirements During Normal Storage	13
4.2 Recharge Requirements When Over Discharged	14
5.Communication interface definition	14
5.1 USB communication port definition	14
5.2 RS485-1/CAN communication interface definition	15
5.3 RS485-2 communication interface definition	15
5.4 RS232 communication interface definition	16
5.5 WIFI QR code	16

01

TECHNICAL DATA

note

Operating current derating according to cell
Voltage and battery temperature

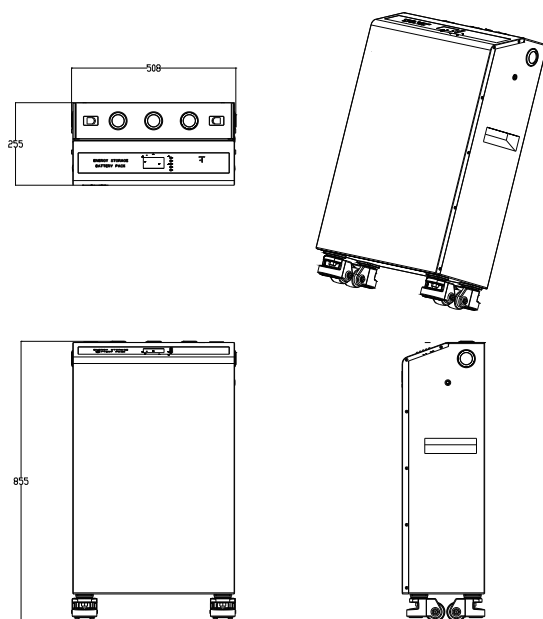

Product parameters

Power supply model	LFB14k-51.2V280AH
Nominal voltage	51.2V
Nominal capacity	14.336KWh/280Ah
Charging protection voltage	56.8V
Discharge protection voltage	46.4V
Maximum charging current	200A
Maximum discharge current	200A
Battery cycle life	≥6000 (25°C±2°C, 0.5C charge-discharge, DOD≥80%)
Communication mode	RS485/RS232/CAN
Charging temperature	5~55°C
Operating temperature	-20~60°C
Battery weight	≈131Kg
Battery size	855x508x255mm (adjustable)
certification	MSDS、UN38.3
Adaptable inverter (can customized)	485: PYLON, DEYE, GROWATT, VOLTRONIC, PACE, LTW, MUST, SRNE, BAYKEE, SMK, AFORE, VKING, BITTA, STONE, EPEVER CAN: PYLON, DEYE, GROWATT, SOLAX, SOFAR, GOODWE, INVT, AFOR, SOLIS, LUXPOWER, VICTRON, SOROTEC, SMA, DONNERGY, MUST, IMEON, SCHNEIDER, GENIXGREEN, INHENERGY, SENERGY, LTW, SUNWAYS, STUDER
*Can be customized according to the needs, the final interpretation of this product is owned by the company, subject to change without prior notice	

02

PRODUCT OVERVIEW

2.1 Brief introduction

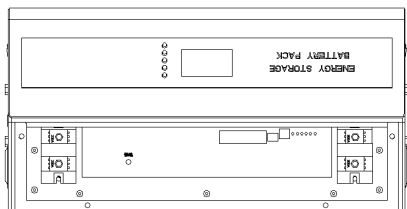

This product is made of 16 Iron(III) phosphate lithium battery cells in series, it is an advanced environmentally friendly household energy storage system, Fashionable design with high energy, long service life, Easy to install and expand.

With rich battery management experience and advanced Energy storage, LFB14k-51.2V280AH Equipped with advanced intelligent Battery management system, The system adopts a modular design, integrating functions such as collection, monitoring, management, and communication, Achieved high-precision single voltage (10mv) / Current collection, Can simultaneously monitor the environment, Temperature changes of battery cells and main heating devices. Extending the lifespan of battery cells and devices, Simultaneously equipped with intelligent charging balance, SOC, Power estimation, Data storage, charging current limiting protection module, LED color light bar display, Pre charging, RS232 communication, CAN communication, RS485 communication and other functions.

2.2 Interface Introduction

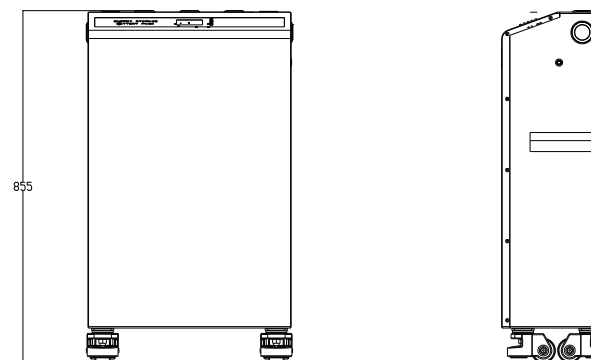

2.2.1 Switch ON/OFF

1. SWITCH ON

When used, Connect the load or inverter end wires to the output end of the battery pack first B+/B-, After confirming the wiring is completed, Turn on the power switch of the battery pack, The battery pack begins to supply power to the load for use.

2. SWITCH OFF

After use, Turn off the load and inverter switches first, Then turn off the battery pack switch.

2.2.2 Interface Introduction

System state	Normal/ Alarm/ Protection	RUN	ALM	Battery indicator LED				illustrate
		●	●	●	●	●	●	
Shutdown	Hibernate	off	off	off	off	off	off	All off
Standby	Normal	flash1	off	According to the battery indicator				Standby
	Alarm	flash1	flash3					Module Low Voltage
Charging	Normal	lighting	off	According to the battery indicator (The highest battery indicator LED flash 2)				The highest battery LED flash (flash2)ALM does not flash when overcharge alarm occurs
	Alarm	lighting	flash3					
	Overcharge protection	lighting	off	lighting	lighting	lighting	lighting	If there is no mains power, the indicator light is in standby mode
	Temperature, overcurrent, and failure protection	off	lighting	off	off	off	off	Stop charging
Discharging	Normal	flash3	off	According to the battery indicator				Stop discharging
	Alarm	flash3	flash3					
	Under voltage protection	off	off	off	off	off	off	Stop charging
	Temperature, overcurrent, short circuit, reverse connection, failure protection	off	lighting	off	off	off	off	Stop charging
Lose efficacy		off	lighting	off	off	off	off	Stop charging and discharging

2.2.3 Explanation of LED light changes

State	Charging				Discharging				
Capacity indicator light	L4●	L3●	L2●	L1●	L4●	L3●	L2●	L1●	
Electricity consumption (%)	0~25%	off	off	off	flash2	off	off	off	lighting
	25~50%	off	off	flash2	lighting	off	off	lighting	lighting
	50~75%	off	flash2	lighting	lighting	off	lighting	lighting	lighting
	75~100%	flash2	lighting	lighting	lighting	lighting	lighting	lighting	lighting
Running lights●	lighting				Flash(Flash 3)				

2.2.4 Power indicator light description

Flashing mode	lighting	off
Flash1	0.5S	3.5S
Flash2	0.5S	0.5S
Flash3	0.5S	1.5S

03 INSTALLATION GUIDE

-In stallation flow chart-

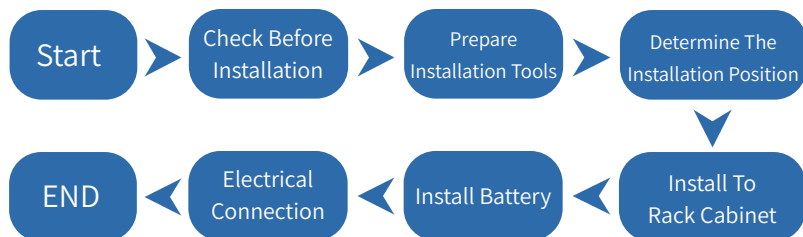

3.1 Checking Before Installation

3.1.1 Checking Outer Packing Materials

Packing materials and components may be damaged during transportation. Therefore, check the outer packing materials for damage, such as holes and cracks. If any damage is found, do not unpack the battery and contact the dealer as soon as possible. You are advised to remove the packing materials within 24 hours before installing the battery.

3.1.2 Cheeking Deliverables

After unpacking the battery, check whether deliverables are intact and complete. If any damage is found or any component is missed, contact the dealer.

The below table shows the components and mechanical parts that should be delivered.

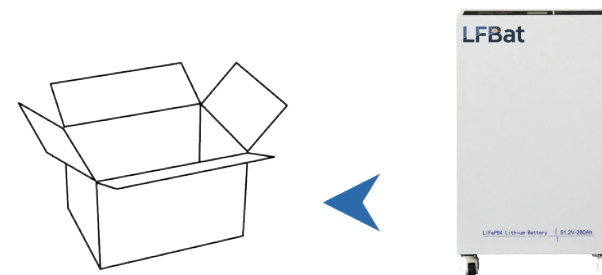

NO	Picture	Quan ty	Descrip on
1		1PCS	Battery
2		1PCS	Positive power cord
3		1PCS	Negative power cord
4		1PCS	485 Communication cable
5		1PCS	Shipment report
6		1PCS	Manual
7		1PCS	Certificate
8		1PCS	Label

3.2 Tools

-Installation-

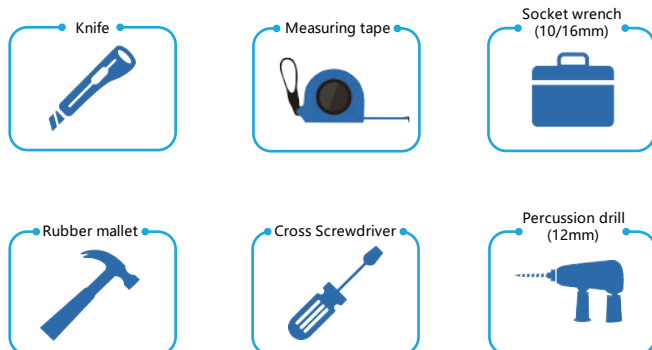

-Protection-



3.3 Installation requirements

3.3.1 Installation environment requirements

- *Install the battery in the indoor environment.
- *Place battery in secure location away from children and animals.
- *Do not place the battery near any heat sources and avoid sparks.
- *Do not expose the battery to moisture or liquids.
- *Do not expose the battery to direct sunlight.

3.3.2 Installation carrier requirements

- *Only mount battery on fire resistant building. Do not install batteries on flammable buildings.
- *Battery is quite heavy, make sure the wall/ground can meet the load bearing requirements.

STEP 1

Connect power cable

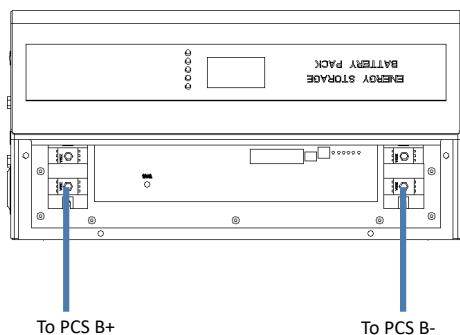

STEP 2

Connect communication cable

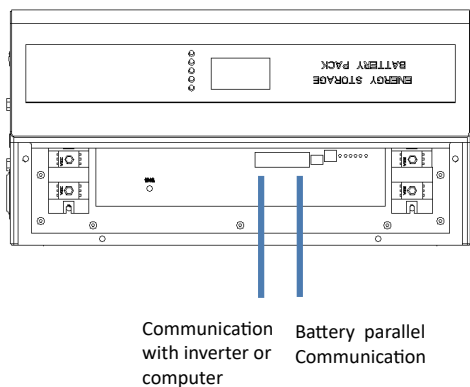

STEP 3

When multiple batteries are connected in parallel, follow the following wiring mode.

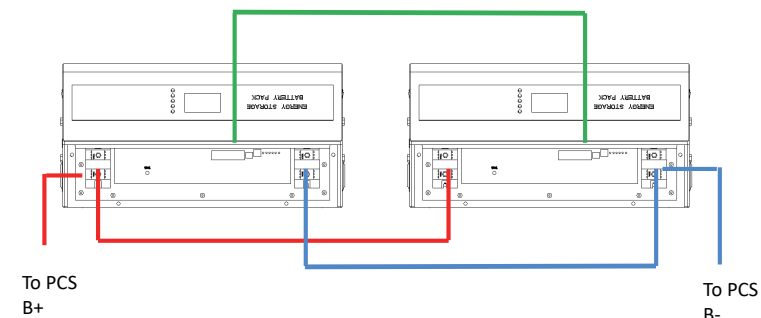

STEP 4

DIP Switch settings



When the pack is used in parallel, Different packages can be distinguished by setting the address through the dial switch on the BMS, To avoid setting addresses to the same, Refer to the table below for the definition of BMS dial switch.

the host address is pack1, and the slave serial number is delayed, Four digit dialing, up to 16

units in total.0000 serves as the host for address 1, 1000~1111 are slaves, There are a maximum of 15 four digit dialing slaves, The host can only communicate with the inverter, and as a slave, there is no inverter communication.

address	Dial switch position			
1	OFF	OFF	OFF	OFF
2	ON	OFF	OFF	OFF
3	OFF	ON	OFF	OFF
4	ON	ON	OFF	OFF
5	OFF	OFF	ON	OFF
6	ON	OFF	ON	OFF
7	OFF	ON	ON	OFF
8	ON	ON	ON	OFF
9	OFF	OFF	OFF	ON
10	ON	OFF	OFF	ON
11	OFF	ON	OFF	ON
12	ON	ON	OFF	ON
13	OFF	OFF	ON	ON
14	ON	OFF	ON	ON
15	OFF	ON	ON	ON
16	ON	ON	ON	ON

04 MAINTENANCE

4.1 Recharge Requirements During Normal Storage

Battery should be stored in an environment with temperature range between -10°C ~ $+45^{\circ}\text{C}$,and maintained regularly according to following table with 0.5C(25A) current till 40% SOC after long storage time.

Recharge Requirements During Normal Storage

Storage Environment Temperature	Relative Humidity of Storage Environment	Storage Time	SOC
Below -10°C	/	prohibit	/
$-10\sim 25^{\circ}\text{C}$	5%~70%	≤ 12 months	$30\% \leq \text{SOC} \leq 60\%$
$25\sim 35^{\circ}\text{C}$	5%~70%	≤ 6 months	$30\% \leq \text{SOC} \leq 60\%$
$35\sim 45^{\circ}\text{C}$	5%~70%	≤ 3 months	$30\% \leq \text{SOC} \leq 60\%$
Above 45°C	/	prohibit	/

4.2 Recharge Requirements When Over Discharged

Over discharged (90%DOD) battery should be recharged according to following table,otherwise over discharged battery will be damaged.

Recharge Requirements During Normal Storage

Storage Environment Temperature	Storage Time	Note
$-10\sim 25^{\circ}\text{C}$	≤ 15 days	Battery Pack disconnected from PCS
$-25\sim 35^{\circ}\text{C}$	≤ 7 days	
$-35\sim 45^{\circ}\text{C}$	≤ 12 hours	Battery Pack connected to PCS

05 COMMUNICATION INTERFACE DEFINITION

5.1 USB communication port definition

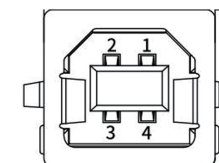

interface	Definitions	
Communication port definition	PIN 1	VBUS
	PIN 2	D-
	PIN 3	D+
	PIN 4	GND

5.2 RS485-1/CAN communication interface definition

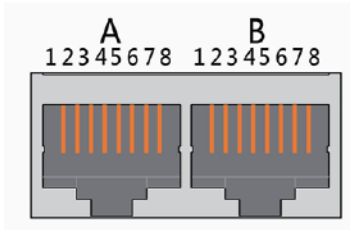

interface	Definitions		Definitions			
X1 Communication port definition	Part A CAN interface	PIN 1	NC (empty)	Part B RS-485-1 interface	PIN 1	RS485-B1
		PIN 2	NC (empty)		PIN 2	RS485-A1
		PIN 3	CGND		PIN 3	RS485-GND
		PIN 4	CANH		PIN 4	RS485-B1
		PIN 5	CANL		PIN 5	RS485-A1
		PIN 6	NC (empty)		PIN 6	RS485-GND
		PIN 7	NC (empty)		PIN 7	NC (empty)
		PIN 8	NC (empty)		PIN 8	NC (empty)

5.3 RS485-2 communication interface definition

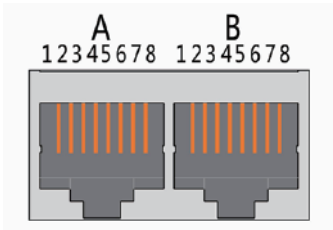

interface	Definitions		Definitions			
X2 Communication port definition	Part A RS-485-2 interface	PIN 1	RS485-B2	Part B RS-485-2 interface	PIN 1	RS485-B2
		PIN 2	RS485-A2		PIN 2	RS485-A2
		PIN 3	RS485-GND		PIN 3	RS485-GND
		PIN 4	NC (empty)		PIN 4	NC (empty)
		PIN 5	NC (empty)		PIN 5	NC (empty)
		PIN 6	RS485-GND		PIN 6	RS485-GND
		PIN 7	RS485-A2		PIN 7	RS485-A2
		PIN 8	RS485-B2		PIN 8	RS485-B2

5.4 Instructions for correspondence

01

USB communication

The USB interface adopts the TYPE B port, through which the BMS can communicate with the host computer, so as to monitor various information of the battery on the host computer, including battery voltage, current, temperature, status, SOC, SOH and battery production information, etc., the default baud rate is 115200bps.

02

RS485 communication

It has 2 RS485 interfaces, both of which are RJ45 network ports, of which RS485-1 is a single port, which is mainly used for data interaction between the battery pack and the inverter, and RS485-2 is a dual port for the data exchange between the cascade and parallel units of the battery pack. At present, the parallel interface can support 32 sets of batteries for parallel operation.

03

CAN communication

The CAN communication interface of the BMS has the ability to interact with the data between the battery pack and the inverter, of which the baud rate is considered to be 500K, and the communication interface is the RJ45 network port.

5.5 WIFI QR code

