

General

- Control device: built in controller
- Product structure: small volume, high current, simple structure, ATS integration
- Features: fast switching speed, low failure rate, convenient maintenance and reliable performance
- Wiring mode: front plate wiring
- Conversion mode: power grid to power grid, power grid to generator, automatics switching and self recovery
- Product frame: 100,160,250,400,630,1000,1250,1600,2000,2500,3200
- Product current: 20,32,40,63,80,100,125,160,200,225,250,315,400,500,630,800,1000,1250,1600,2000,2500,3200A
- Product classification: load switch type
- Pole No.: 3,4
- Standard: GB/T14048.11-2016
- ATSE: PC class

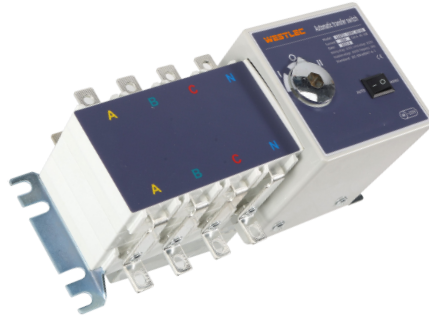

Product Overview

- ★ CAATS1 Automatic transfer switch (ATSE) is set the switches and control logic integrated without additional controller, achieve integration of automatic electromechanical switch. It has functions such as voltage detection, electrical and mechanical interlocking, and can achieve automatic and emergency manual control.
- ★ This is the logical control panel from various logical order to manage the machines, operate with the gearbox to achieve, switching spring motor storage, instantaneous release of the acceleration, rapid access to sub-circuit or circuits conversion, it is obvious by the state security confinement, greatly improved the performance of various electrical and mechanical properties.
- ★ The switches overall design for the metal shell, compact solid. Control of the switch is mental shell and the switch has strong dielectric performance, protection ability and reliable operation safety.
- ★ Switch power supply system applicable to changeover the main power supply and backup power supply automatically or two sets load equipment and safety isolation automatically.
- ★ Switch appearance is beautiful, creative, simple, small size, the entire function is an ideal choice in different occasions.

Meeting the standards

- ★ IEC60947-1(1998)/GB/T14048.1-2002 "Low voltage switchgear and control equipment General rules"
- ★ IEC60947-3(1999)/GB14048.3-2002 "Low voltage switchgear and control equipment, low voltage switch, isolator, disconnecter and fuse combination apparatus"
- ★ IEC60947-6(1999)/GB14048.11-2016 "Low voltage switchgear and controlgear multifunction electrical apparatus part 1: automatic transfer switchgear"

Scope of application

- ★ CAATS1 series dual power automatic transfer switch is mainly applicable to the AC 50Hz, rated voltage AC400V, working voltage 220V, rated current 16A to 3200A distribution or generator network. There is a primary and standby power, or as the utility to generator in loading changeover. At the meanwhile, it can be used for isolation of infrequently connecting and breaking circuits and lines.
- ★ This products are widely used in hospitals, banks, high-rise architecture and so on, which are very important place disallow the failure to supply, distribution and automation system.

Performance and characteristics

- ★ Adopt the double row type composite contact, side pull institutions, micro motor prestore and microelectronics control technology, come true zero flashover(no arcing chamber).
- ★ Reliable electrical and mechanical interlocking chain, the implement of the components independently with isolation switch, the use of safe and reliable.
- ★ Using over zero technology, the state of emergency can be enforced under the zero(cut down the 2 ways in the meanwhile) to meet the needs of fire fighting.
- ★ Executive load isolation switch using a single motor-driven, transfer reliable smooth, no noise, little impact.
- ★ Operators drive only in the implementation of the electrical load isolation by switching transient current, steady work without providing current, energy-saving significantly.
- ★ Executive load isolation switch with a mechanical device used to ensure that reliable standby power of non-interference in each other.
- ★ Obvious on-off position indication, padlocks and other functions, high reliability and service life of more than 8000 times.
- ★ Mechatronics design, switching conversion accurate, flexible, smooth and adopt international advanced logic control technology, anti-interference capability, without external interference.
- ★ Cooperation with the main power on and standby power off, or the main power off and standby on, the main power and standby power are both off, three kinds stability working(I-O-II).
- ★ Easy installation, the control circuit return way adopt the connect and insert terminal connector.
- ★ Four operator models: emergency manual operation, electric remote control operation, emergency disconnected operation under the automatic stating, automatic control operations.

Switch structure description

1. Electrical key lock: control switch internal control circuit power supply, when the electrical lock is opened, the switch can realize full-automatic, force '0' and remote operation. When the electric lock is closed, the switch can only be operated manually.
2. Operating handle: when using the operating handle for manual operation, the electric lock must be closed first.
3. Mechanical padlock: it is a special padlock mechanism for maintenance. When repairing, turn the switch to "0" position, and then pull up the padlock mechanism put on the padlock. It can prevent any accident (pulling up the padlock will cut off the internal control power supply of the switch, and the switch can not automatically. At the same time, it can prevent the handle from being covered).
4. Indicator: indicating the three states (I, 0, II) of the switch.

Dual Power Automatic Transfer Switch

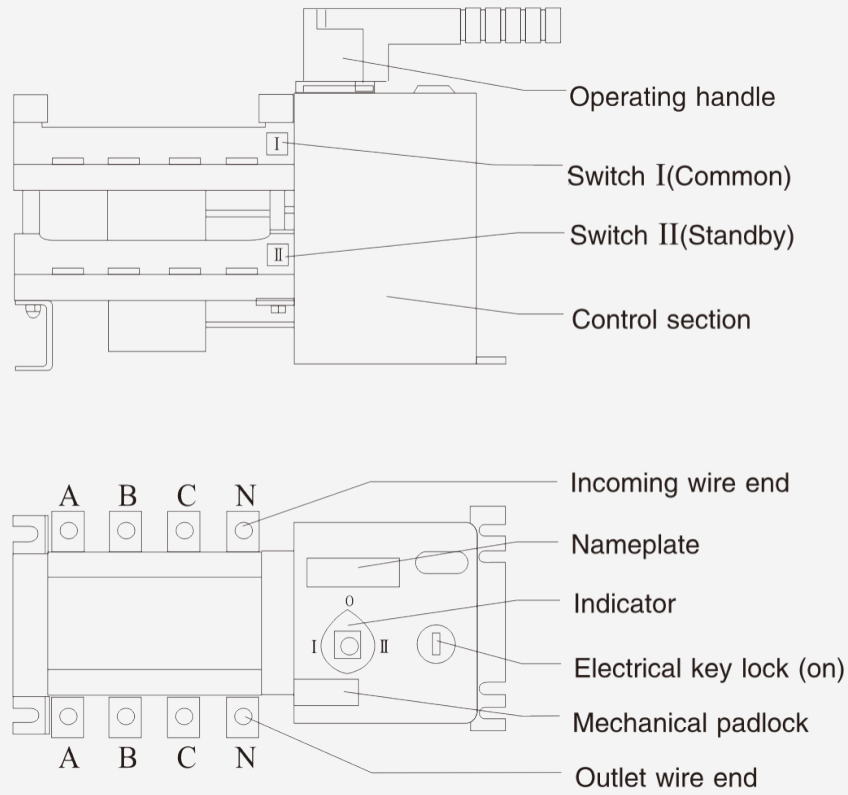

Main circuit wiring diagram

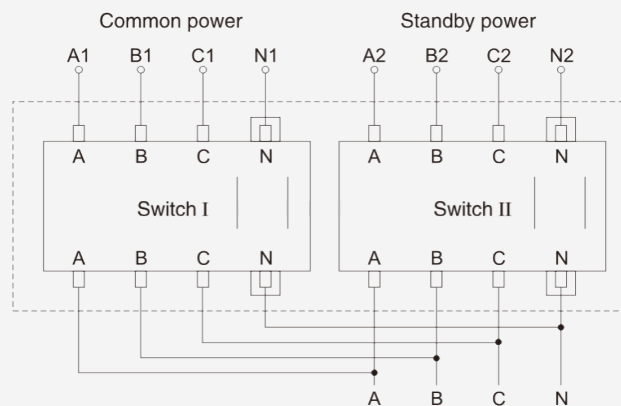

Dual Power Automatic Transfer Switch

Main technical parameters

■ Electrical and mechanical properties of dual power automatic transfer switch

Rated current		20 A	40 A	63 A	80 A	100 A	125 A	160 A	250 A	400 A	630 A	800 A	1000 A	1250 A	1600 A
Rated insulation voltage	750V									1000V					
Rated impulse withstand voltage	8kV									12kV					
Rated working voltage	AC400V														
Rated working current	AC-31A	20	40	63	80	100	125	160	250	400	630	800	1000	1250	1600
	AC-35A	20	40	63	80	100	125	160	250	400	630	800	1000	1000	1600
	AC-33A	20	40	63	80	100	125	160	250	400	400	630	800	800	1000
Rated making capacity	10Ie														
Rated breaking capacity	8Ie														
Rated limited short circuit power supply	50kA									70kA			100kA	120kA	
Rated short time withstand power supply	7kA						9kA		13kA		26kA		50kA		
Conversion time I-II or II-I	0.45s									0.6s		1.2s			
Control voltage	AC220V														
Motor energy consumption															
Rated power	Start	300W						325W		335W		400W	440W		
	Normal	55W						62W		74W		90W	98W		
Weight	7.0	7.2	7.2	7.2	7.5	7.5	8.8	9.0	16.5	17	32	36	40	43	

Overall and installation dimension

Overall and installation dimension drawing(100 ~ 1600)

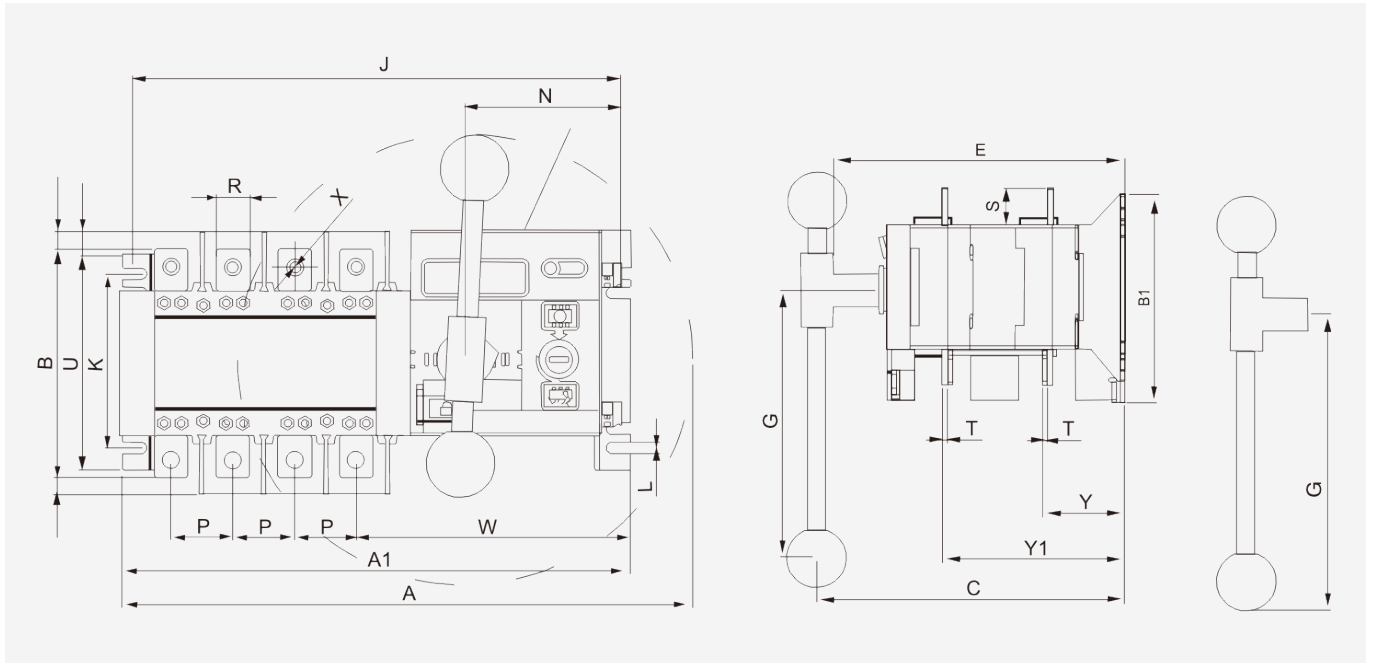

1000 ~ 1600 Installation diagram

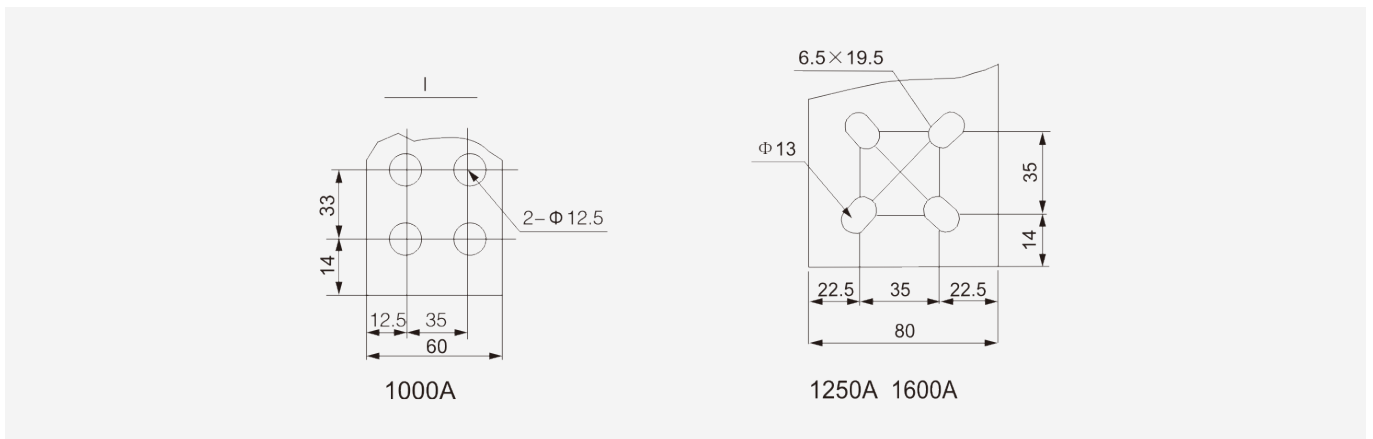

Dual Power Automatic Transfer Switch

100 ~ 1600 Installation dimension table

Spec.	Total size							Switch installation									Connecting terminal			
	A	A1	B	B1	C	E	G	J	K	L	N	P	R	S	T	U	W	φX	Y	Y1
100/3	235	232	118	107	141	140	115	221.5	84	7	74.5	30	13	18	2.5	107	126	6	39	92
100/4	247	244	118	107	141	140	115	233.5	84	7	74.5	30	13	18	2.5	107	126	6	39	92
125/3	292	267	146	142	230	193	145	251	102	7	91	36	20	25	3.5	126	158	9	57	127
125/4	322	300	146	142	230	193	145	284	102	7	91	36	20	25	3.5	126	158	9	57	127
160/3	292	267	146	142	230	193	145	251	102	7	91	36	20	25	3.5	126	158	9	57	127
160/4	322	300	146	142	230	193	145	284	102	7	91	36	20	25	3.5	126	158	9	57	127
250/3	356	305	179	142	230	193	145	287	102	7	91	50	25	30	3.5	135	168	11	58	130
250/4	406	360	179	142	230	193	145	343	102	7	91	50	25	30	3.5	135	168	11	58	130
400/3	487	375	245	220	274	263	189	356	180	9	93	65	32	39	5	220	203	11	82	186
400/4	552	433	245	220	274	263	189	416	180	9	93	65	32	39	5	220	203	11	82	186
630/3	487	375	265	220	274	263	189	356	180	9	93	65	40	49	5	220	203	12	82	186
630/4	552	433	265	220	274	263	189	416	180	9	93	65	40	49	5	220	203	12	82	186
800/3	670	515	353	250	321	308	443	495	220	11	87	120	60	54.5	8	250	207	13	107	240
800/4	760	636	353	250	321	308	443	616	220	11	87	120	60	54.5	8	250	207	12.5	107	240
1000/3	670	515	353	250	321	308	443	495	220	11	87	120	60	54.5	8	250	207	13	107	240
1000/4	760	636	353	250	321	308	443	616	220	11	87	120	60	54.5	8	250	207	12.5	107	240
1250/3	670	515	367	250	321	308	443	495	220	11	87	120	80	68	8	250	207	13	108	240
1250/4	760	636	367	250	321	308	443	616	220	11	87	120	80	68	8	250	207	13	108	240
1600/3	670	515	370	250	321	308	443	495	220	11	87	120	80	69	10	250	207	13	108	240
1600/4	760	636	370	250	321	308	443	616	220	11	87	120	80	69	10	250	207	13	108	240

2000 ~ 3200

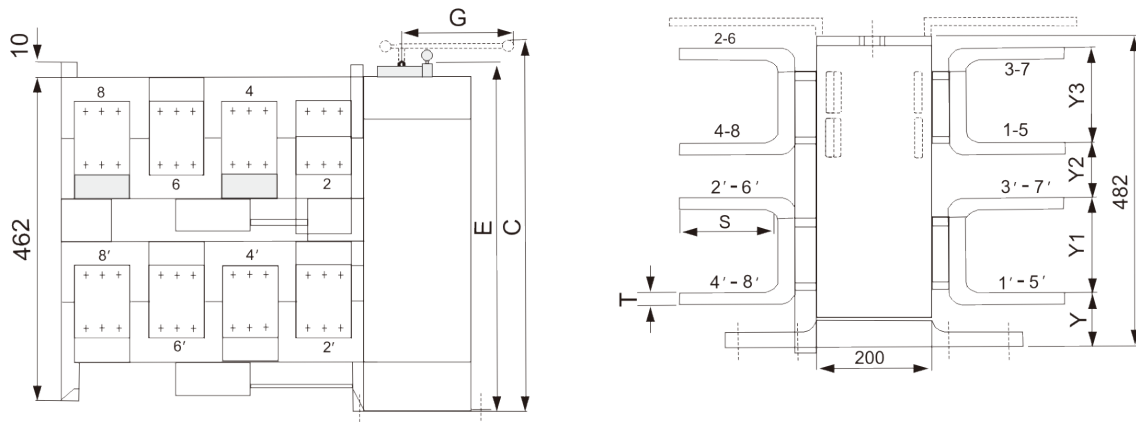

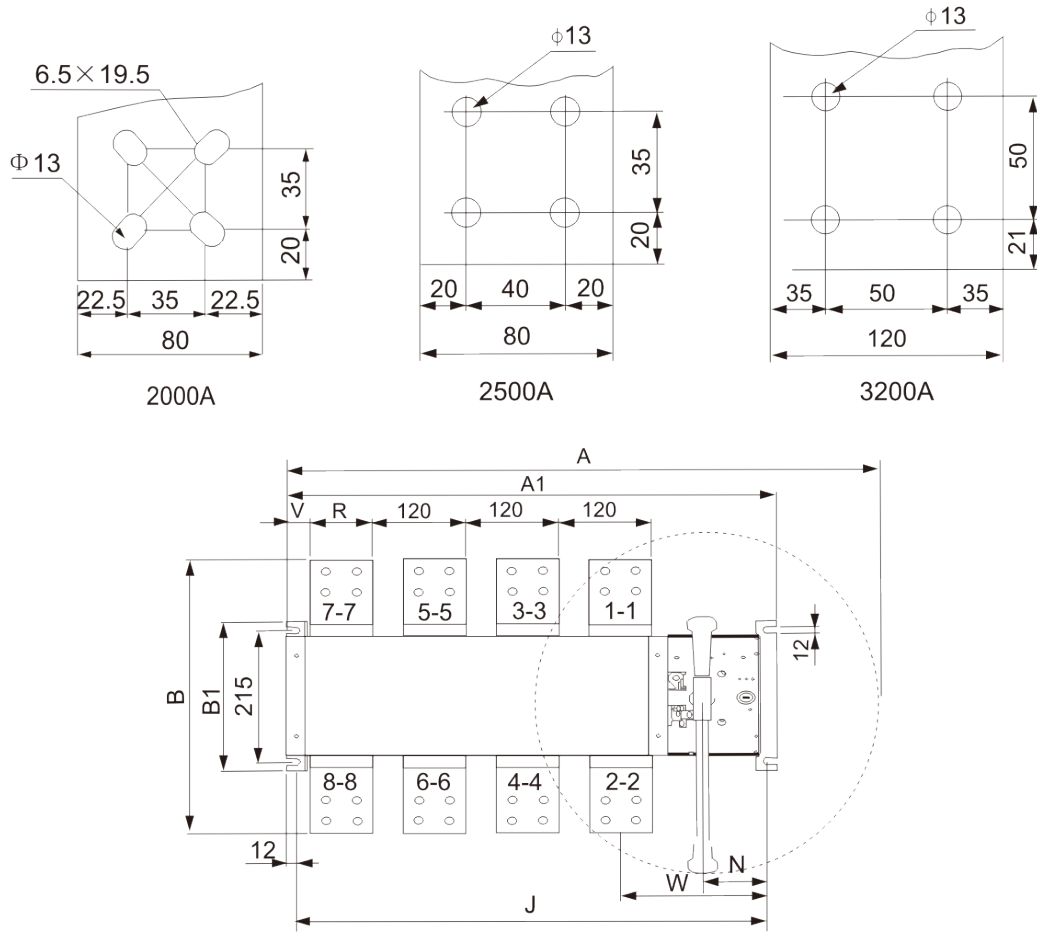

■ 2000 ~ 3200 Installation dimension table

Spec.	Total size							Switch installation					Connecting terminal				
	A	A1	B	B1	C	E	G	J	N	R	S	T	W	Y	Y1	Y2	Y3
2000/3	680	525	405	254	480	467	447	498	84.5	80	76	10	204.5	105	87	125	88
2000/4	800	646	405	254	480	467	447	618	84.5	80	76	10	204.5	105	87	125	88
2500/3	680	525	427	254	480	467	447	498	84.5	80	80	15	204.5	98	100	116	100
2500/4	800	646	427	254	480	467	447	618	84.5	80	80	15	204.5	98	100	116	100
3200/3	680	525	458	254	480	467	447	498	84.5	120	95	15	204.5	98	107	109	106
3200/4	800	646	458	254	480	467	447	618	84.5	120	95	15	204.5	98	107	109	106

Dual Power Automatic Transfer Switch

Switch wiring method

Note: The customers can choose one of the following 6 wiring methods, economical type users only need to import the copper power, then do not need another 2 lines, 302-305 is the indication of the switch, users can connect themselves if needed.

1、Wiring method of economic type(only below 100A)

100A economic type automatic transfer switch, users connect the main power, standby power to the terminal rafts then it can work. When the two-way power switch are all normal access to the main power supply for the load. If the power supply is failure, then will transfer to standby power (standby power should be normal), it will change back to main power when the main power is normal again.

The economic type below 100A, control power directly from the mains supply by the manufacturer within the introduction. If users need the main power supply, standby power switch on instructions, wiring method see as below:
Terminal wiring method: Only a group of six terminal

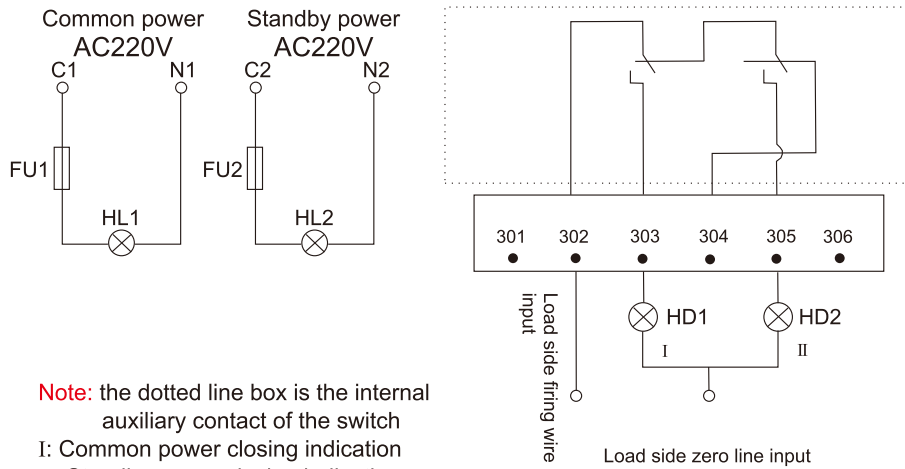

Note: the dotted line box is the internal auxiliary contact of the switch
I: Common power closing indication
II: Standby power closing indication

When the switch is three pole, 301 shall be connected to the common neutral line (N) and 306 shall be connected to the standby neutral line (n).

Dual Power Automatic Transfer Switch

2、 100 ~ 630 Passive signal + active fire terminal connection mode

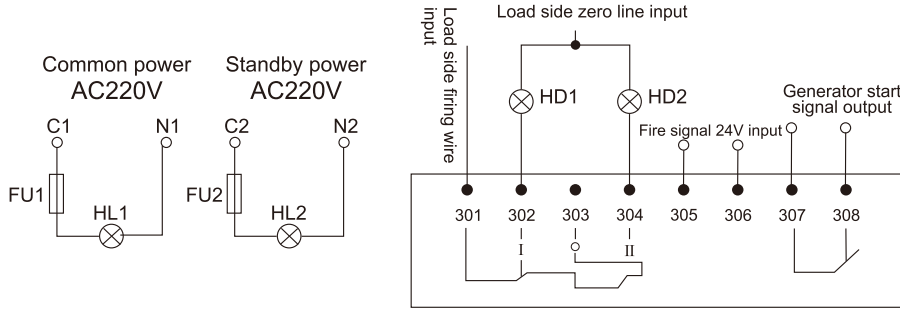

3、 Fully automatic connection mode (applicable to rated current 160A ~ 3200A)

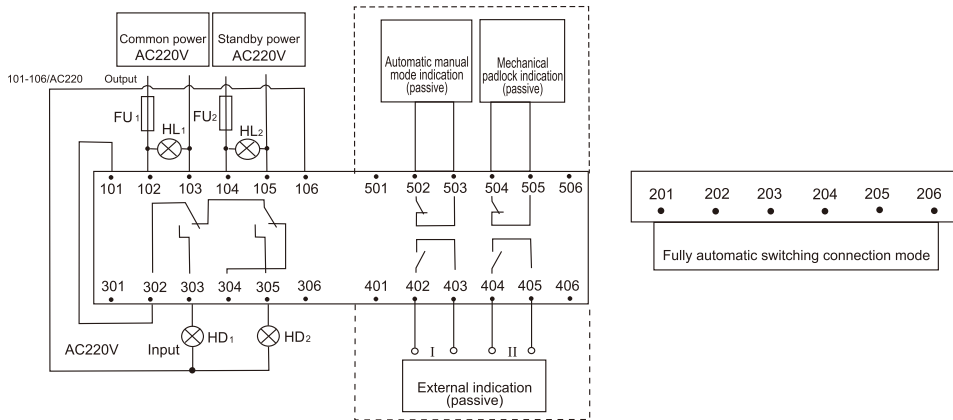

- HL1 is the indication of common power supply;
- HL2 is the indication of standby power supply;
- HD1 is the common power input indication;
- HD2 is standby power input indication.
- New type FU1/FU2 is 2A fuse;
- 101 ~ 106, 201 ~ 206, 301 ~ 306 are switch terminals;
- 401 ~ 406, 501 ~ 506 switch terminals above 1000A can be selected.

4、 100 ~ 3200 Full automatic + forced setting "0" (both power sources are disconnected) connection mode

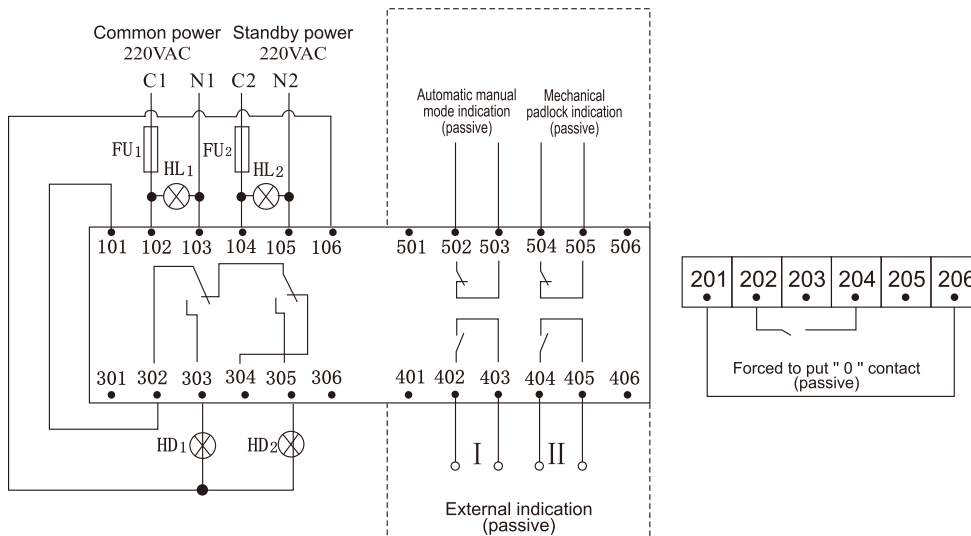

Dual Power Automatic Transfer Switch

■ 5、100 ~ 3200 Fully automatic + generator signal output connection mode

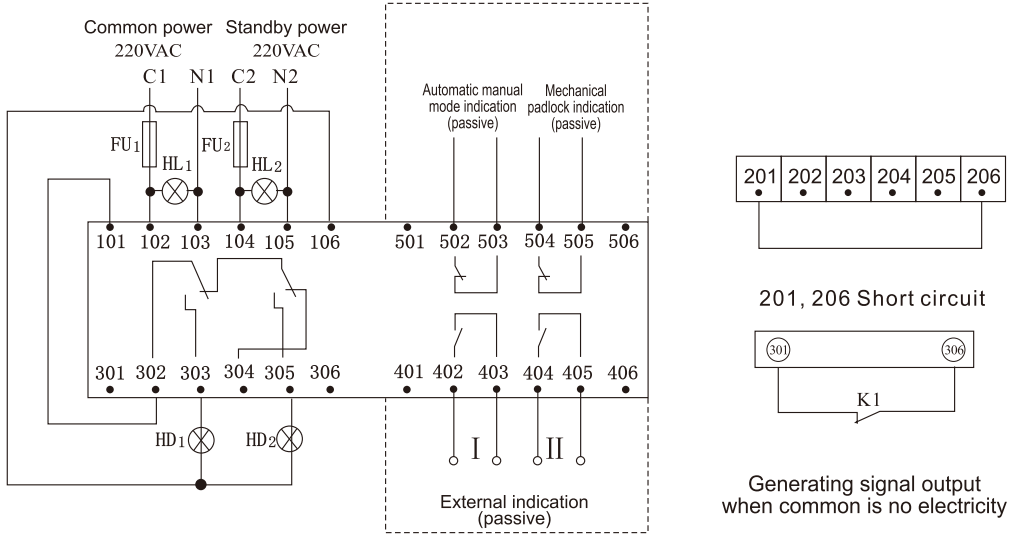

■ 6、Fully automatic + Manual (remote control) connection mode

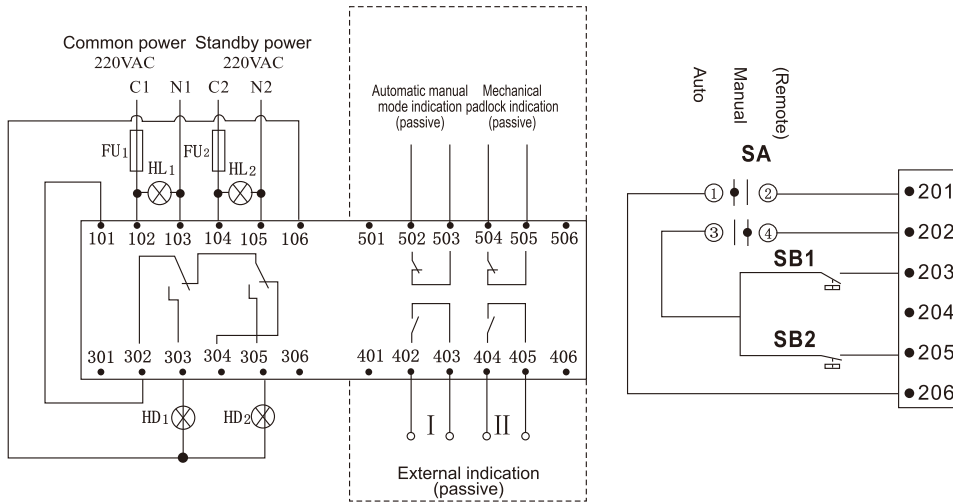

Dual Power Automatic Transfer Switch

7、 100 ~ 3200 Wiring mode with controller

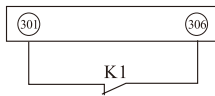
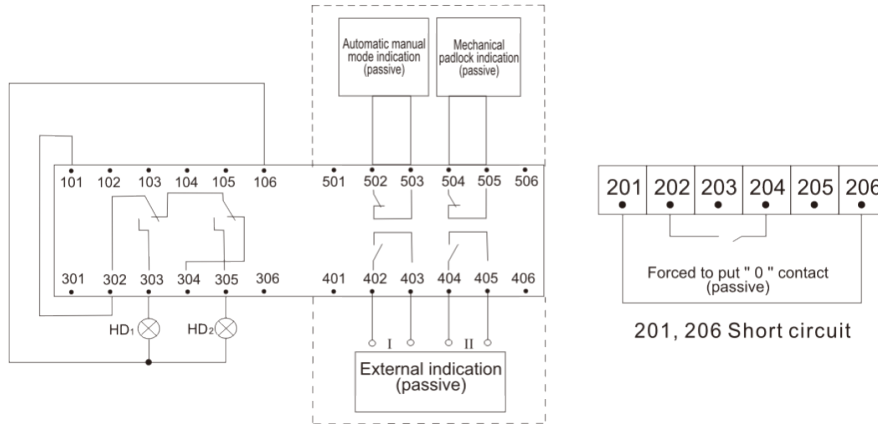

Generating signal output when common use is no electricity

- Note:**
1. Products with controller 102, 103, 104, 105 do not need external power supply;
 2. 401-406, 501-506 switch terminals above 1000A can be selected.

8、 Explanation of letters and symbols

- (1) C1 and N1 are common power input firing line and zero line access, C2 and N2 are standby power input firing line and zero line access respectively. HL1 and HL2 are common power supply and standby power supply with electric indication. HD1 and HD2 are input indication of common power supply and standby power supply respectively. FU1 and FU2 are 2A fuses;
- (2) 101 ~ 106 and 201 ~ 206 are secondary terminals of automatic transfer switch;
- (3) 301 ~ 306 are external indicator light terminals of automatic transfer switch;
- (4) 401 ~ 406 and 501 ~ 506 automatic transfer switch terminals can be selected;
- (5) The fully automatic connection mode 201 and 206 must be short circuited;
- (6) The forced to put "0" contact (passive) can also input DC24 V power supply;
- (7) K1 is the output of power generation signal(when common use is no electricity);
- (8) SA is the automatic / manual function selection switch, SB1 and SB2 are the common power supply respectively, and the standby power supply manual input button (passive contact).

Method of terminal connection

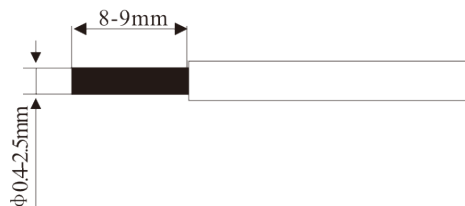
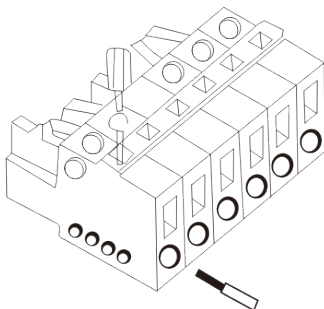

Use the screw driver use force downwards as the picture indicated direction, the line imbedding as the picture shows

Correct installation method of switch

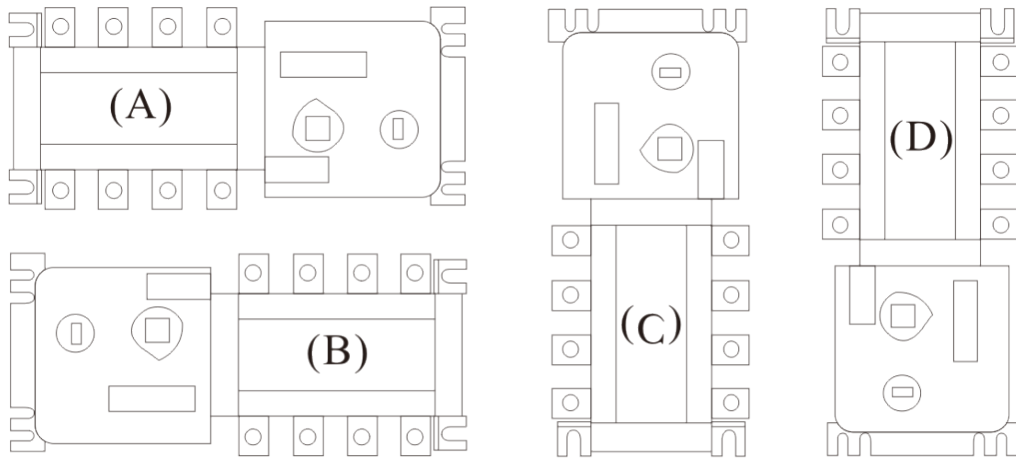

The above A.B.C is correct (A is the best), and D is incorrect.

Switch operating instructions

1. Please do not install it if you are not a professional. Do not disassemble it without permission of our company to avoid damage.
2. Please read this manual carefully before installation to avoid improper use.
3. The rated voltage of switch internal control power supply is 220V, which is taken from C1.N1 of common power supply and C2.N2 of standby power supply. In 85% - 110% of the rated control voltage range, the switch can work normally.
4. The power supply at the incoming end of the switch shall be protected against over-voltage to avoid damaging the internal circuit board or control motor due to high voltage.
5. The power supply at the outlet end of the switch shall be protected against short circuit, so as to avoid burning the switch body due to excessive current during short circuit.
6. When using and installing, please turn off the electric key lock and turn the switch to the "0" position.
7. When the switch is connected, please measure and distinguish the A.B.C.N of the power incoming line and connect it to the corresponding pole of the switch.

Overview

The CA2R dual power automatic transfer switches, a newly developed and innovative solution for household power transfer. These switches are designed to test the normal and standby power supply, ensuring that backup power is readily available in case of any abnormalities. Specifically designed for rail-noise power distribution boxes, this product is perfect for households looking for a reliable and safe power supply.

CA2R automatic transfer switches are suitable for emergency power systems 400V, 125A with AC rated current of 50V or 60Hz compact structure, reliable conversion, easy installation, and maintenance. long life. It is widely used in various occasions where continuous power failure is not allowed. It can be operated electrically or manually by ATS, and the controller.

This product complies with the requirements of Low-voltage Switch Gear and Control Gear, as specified by IEC60947-6-1 and IEC60947-3 for functional equipment and transfer switch equipment. Choose the EK2R dual power automatic transfer switches for uninterrupted power supply and peace of mind.

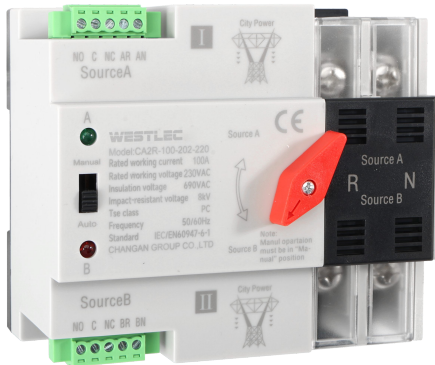

Product Model and Classification

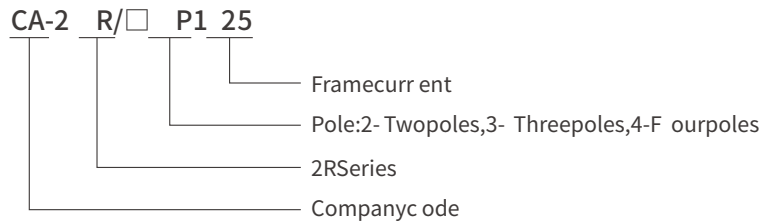

Technical Data

Rated current Ie	16,20,25,32,40,50,63,80,100,125A
Insulation voltage Ui	AC690V
Rated voltage Ue	2P:A C230;3P,4P:A C400V
Class	PC class: c, anbeswit chedonandlo adedwithoutg enerating short -circuit current
Use category	AC-33iB
Life	Electrical:2000times;Mechanical:5000times
Rated condition short-circuit current Iq	50kA
SCP (fuse)	RT16-00-63A
Rated impulse withstand voltage	8kV
Control circuit	Rated control voltage Ue: A C220V, 50Hz; Correct working condition 85%Ue~110%Ue
Auxiliary circuit	AC220V/AC110V50/60Hz
Contact transfer time	<50ms
Operating transfer time	<50ms
Return transfer time	<50ms
Off-time	<50ms
Temperature range	-5°C~+40°C average temperature no more than 35°C in 24 hours

Contour Dimensions and Installation Dimensions

- ① Control power
- ② Selection switch (Auto/manual)
- ③ Manual knob
- ④ Normal power main circuit terminal
- ⑤ Alternative power main circuit terminal
- ⑥ Load side main circuit terminal
- ⑦ Power A indicator
- ⑧ Power B indicator

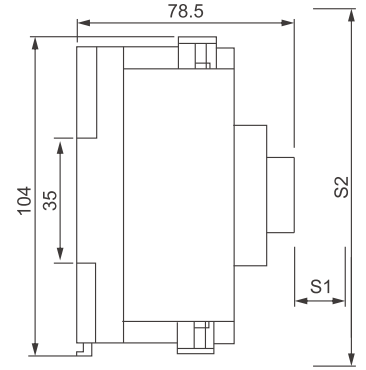
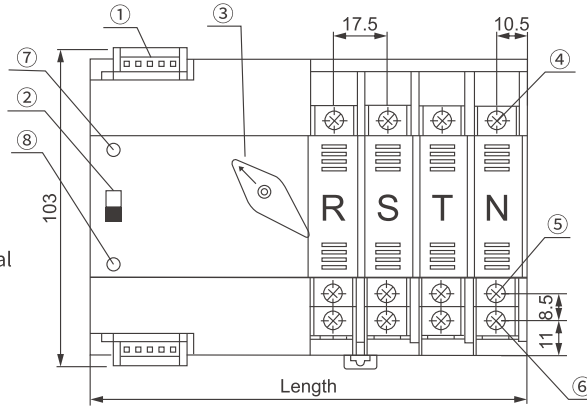

Safety distance: S1>30mm, S2>203mm

Table dimensions

Pole numbers	2P	3P	4P
Length	107.5	125	142.5

Panel Description

Normal type:
Source A: City power
Source B: Backup power

Note:
For solar type, the backup power must be connected to the city power.

Solar type:
Source A: PV (AC power by inverter)
Source B: Must be connected to the city power

C-NC: Generator start signal contact

Rated control voltage Us: AC220~230V;
If the product is using under the condition of voltage less than 190V, it will burn.

Rated control voltage Us: AC110V;
If the product is using under the condition of voltage less than 95V, it will burn.

Suggestion: It is best to add over-voltage and under-voltage protectors of the circuit.

Wiring Diagram of Controller

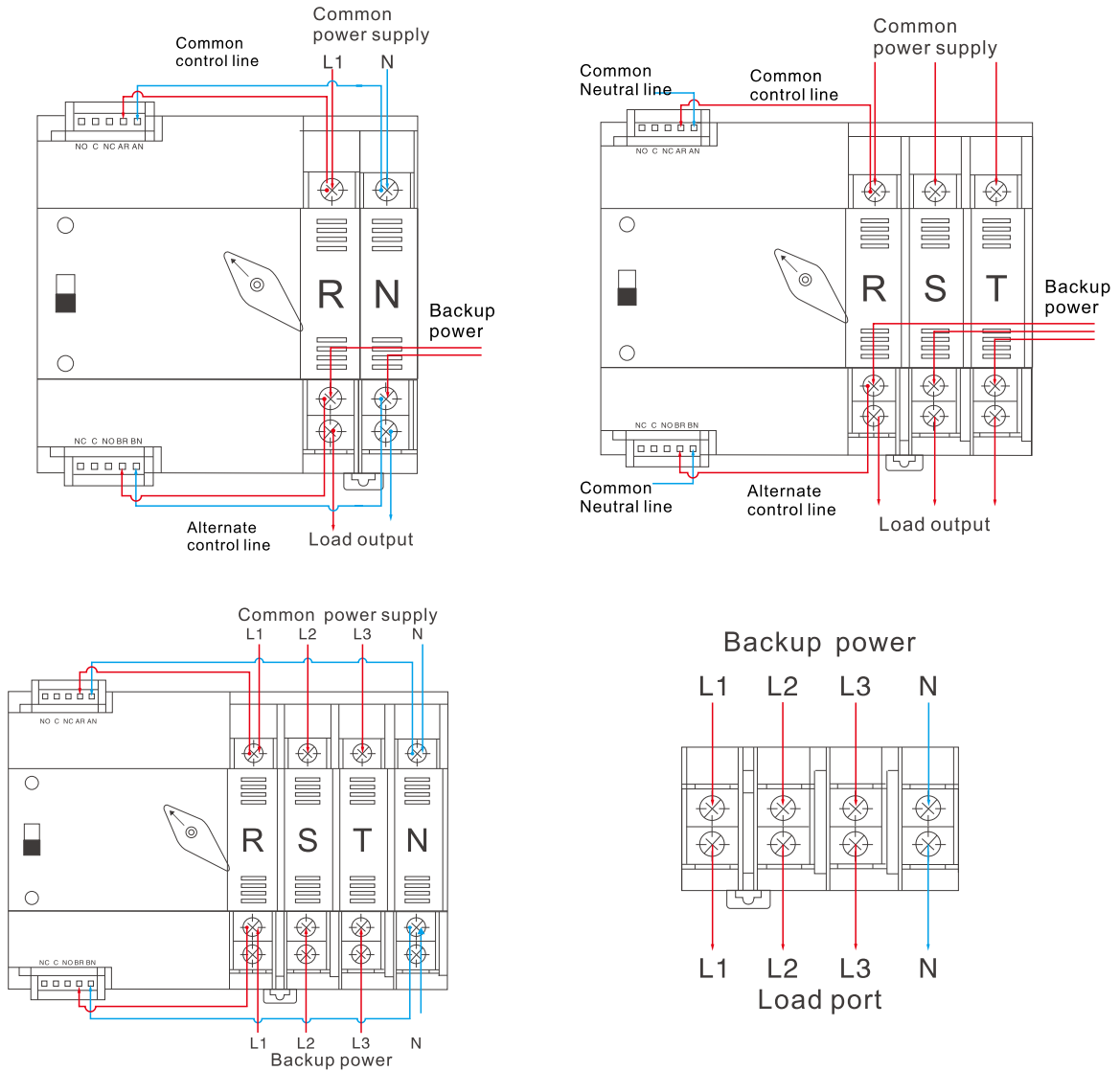

- (Must be connected) Take zero line and fire line from the common control incoming line to connect AR (live wire) / AN (neutral line);
- (Must be connected) Take zero line and fire line from the backup control incoming line to connect BR (live wire) / BN (neutral line);
- The power indication signal is passive output, and the generator signal is taken (common) and (normally closed);
- Connect the load end at the lower end of the (standby power supply side), Stepped wiring;
- There is an isolation board on the load. When wiring, first remove the isolation board. connect the load and then install the isolation board (it is recommended to connect the load first, then connect the backup power supply).

Note: Normal type wiring same as solar type. For solar type, the backup power must be connected to the city power.